

- HIGH CROSSTALK ATTENUATION.
- VOICE & DATA TELECOM APPLICATIONS.
- DESIGNED FOR WET (90mA DC) CIRCUITS.
- HIPOT 1500Vrms.
- IMPEDANCE RATIO OF 600Ω : 600Ω.
- IDEAL FOR MULTIPLE RACK APPLICATIONS.
- UL RECOGNIZED COMPONENT - UL 1863, FILE E138250.
- ALTERNATE HIGHER PERFORMANCE PART, SPT-125.

REVISIONS			
DATE	REV	DESCRIPTION	APPV'D
09-24-93	-1	Chg'd THD Spec. was specified in % distortion	TJK
03-28-16	-2	Update Drawing - added millimeters	Tjk

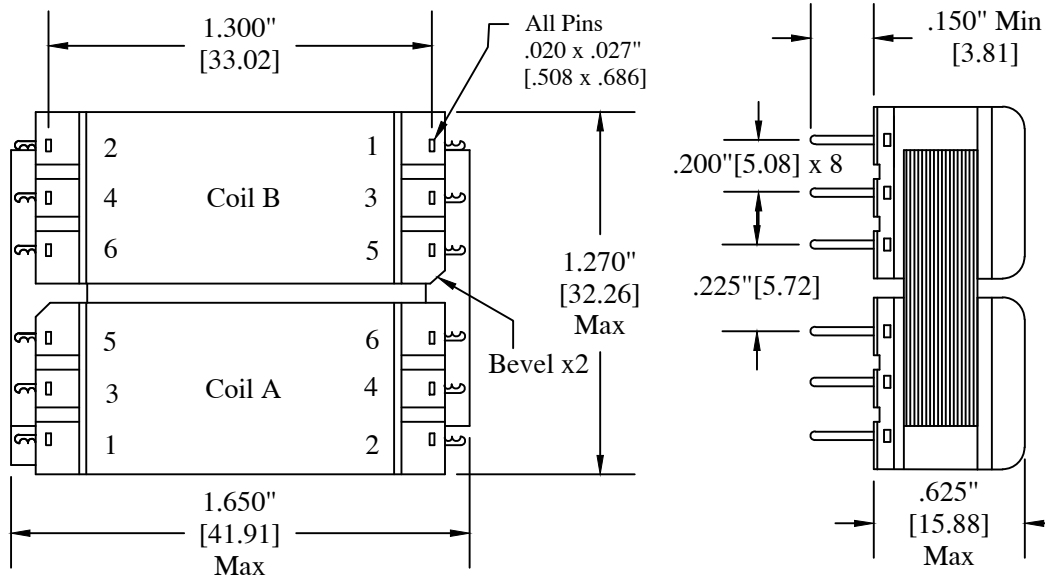

Electrical Parameters

Primary Impedance: 600 Ohms
 Secondary Impedance: 600 Ohms
 Max DC Unbalance: 90mA
 Turns Ratio: 1:1 ±2%
 Dielectric Strength: 1500Vrms P-S-C
 Frequency Response: ±0.5dB 300 -3.5KHz (1KHz Ref.)
 Return Loss: 12.0dB Min. @ 300Hz
 Insertion Loss : (Ref. @ 1KHz) 1.40 dB
 Primary D.C.R. : 80.0 Ω ±10% Total
 Secondary D.C.R. : 100.0 Ω ±10% Total
 THD: 0dBm @ 300Hz Input, -53dB Typ.
 Longitudinal Balance: 60dB minimum per IEEE #455-1985

Note : Reflected Z = 755 Ω Ref. @ 1KHz, 0mA Dc./ Pri. 600 Ω Load/ Sec.

Note: This unit is symmetrical and can be rotated 180° with out changing the Pin-Out or electrical performance

All dimensions are reference unless otherwise specified.

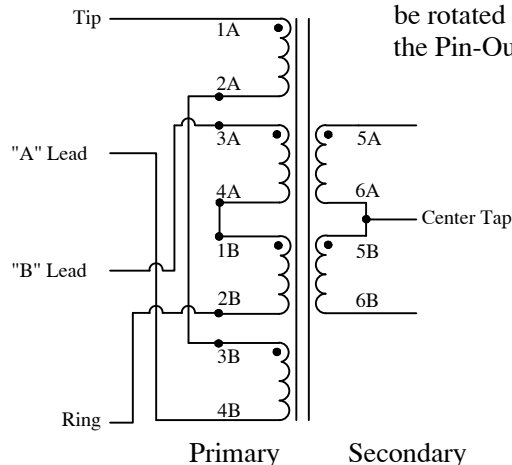

Necessary External connections : 2A - 3B
4A - 1B
6A - 5B

PREM MAGNETICS INCORPORATED		CUSTOM ENGINEERING MAGNETIC COMPONENTS Johnsburg, Illinois 3521 N. Chapel Hill Rd. / McHenry, Illinois 60051	
SCALE: None	APPROVED BY: <i>Tj Klotz</i>		DRAWN BY Tjk
DATE: 03-28-2016			REVISED
Mechanical / Electrical Drawing for Part SPT-194			
			DRAWING NUMBER B SPT-194-2